

# SEVERE DUTY

## Relay Box



## OPTIONAL Add-On Equipment:

The Circuit Breaker, Weatherproof Relay, connectors and terminals shown below, are just a small sample of the many accessories that are available to help with your installation, from the American Autowire Catalog.

### UNSEALED CONNECTORS

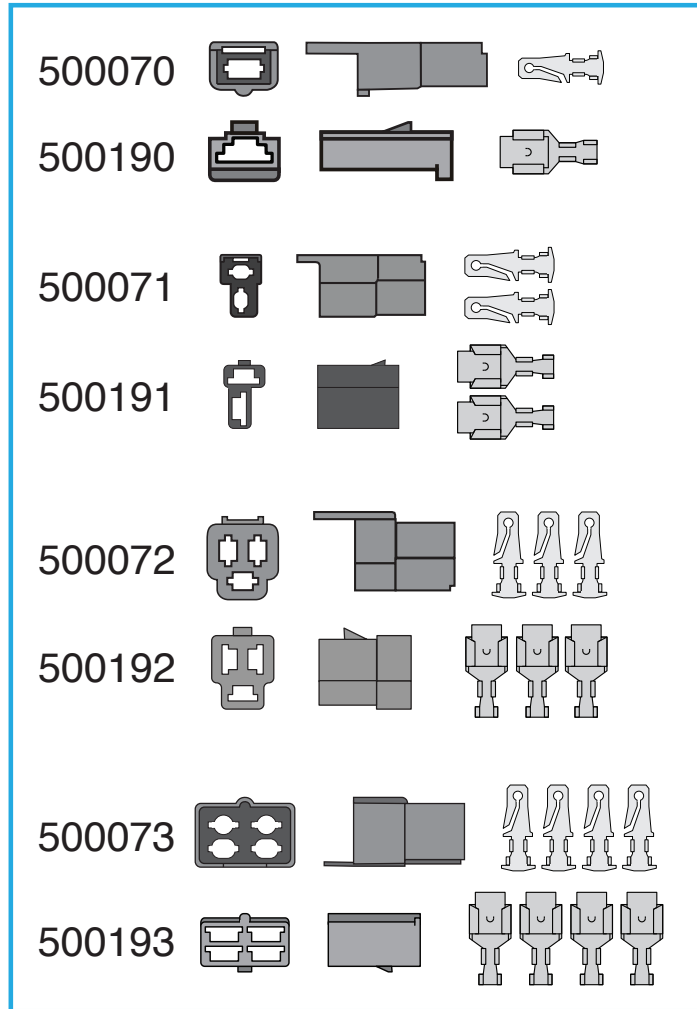

### SEALED WEATHER PACK CONNECTORS

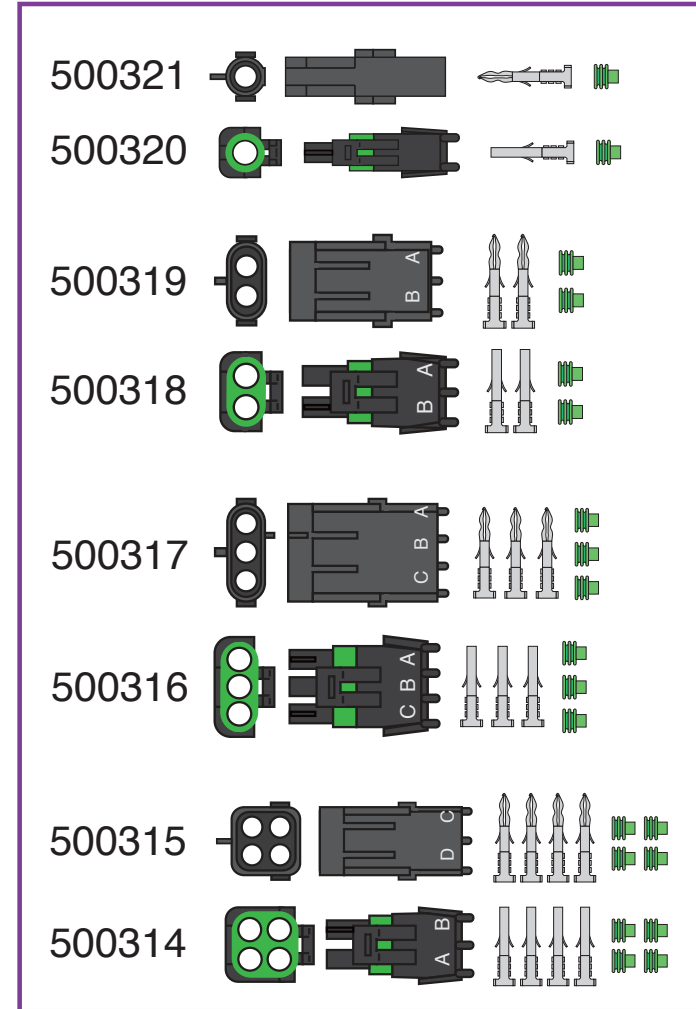

## FIND THESE PARTS, IN SUPPLIED BAG A:

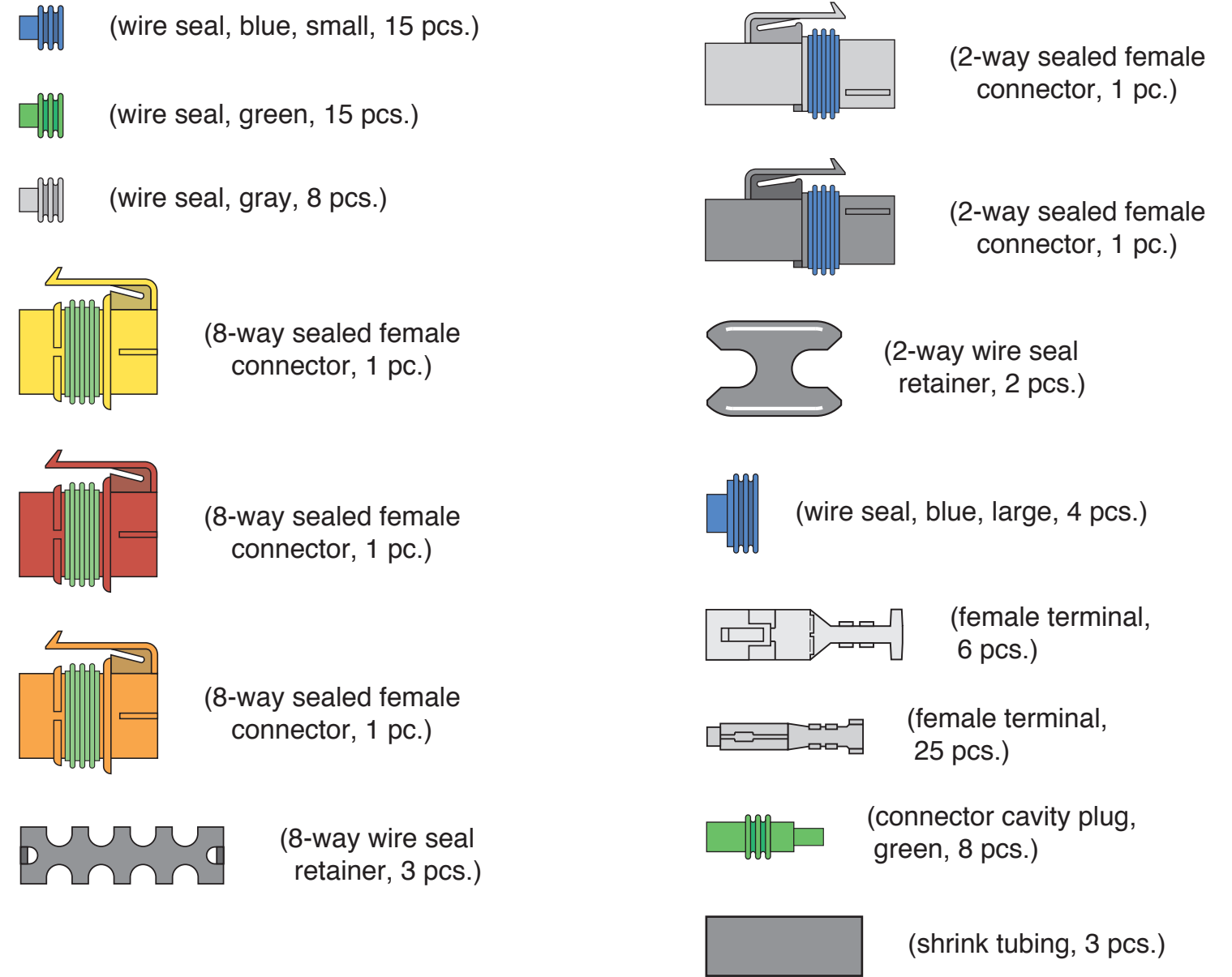

**510598**  
200 Amp Circuit Breaker  
Manual Reset



**510602**  
60 Amp  
Weatherproof Relay

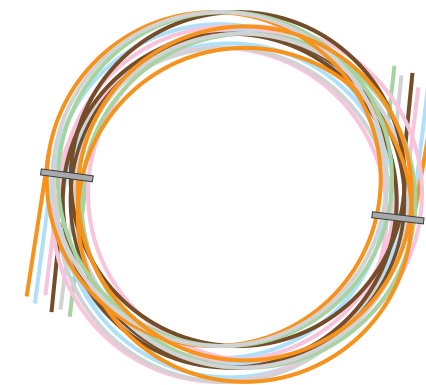

(18-14 Ga. wires)

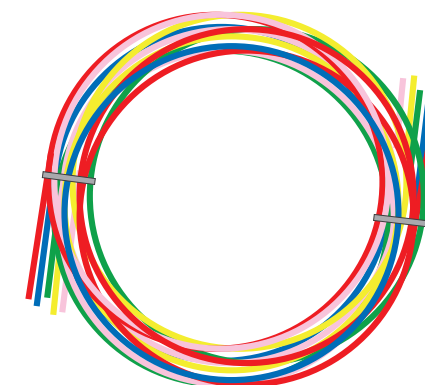

(12 Ga. wires)

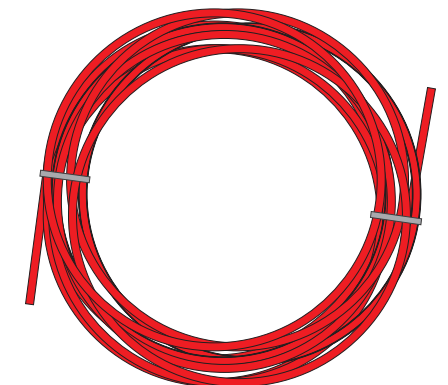

(10 Ga. wire)

# START HERE !

## PLEASE READ THIS BEFORE STARTING INSTALLATION !

This wiring kit is designed for ease of installation. Please read the guidelines below, BEFORE STARTING your installation, to guarantee a successful job. Use an appropriate crimping tool, which folds the wings of the open barrel terminals down into the wire, as shown on this page. If you use our crimping tools and correctly crimp the included terminals, soldering is not necessary. If you are unsure about a particular crimp, soldering is recommended. Our factory crimped terminations are installed by GM approved five ton presses, and soldering these terminations is not necessary.



AAW offers a great terminal crimping video entitled "Proper Crimping Video". It can be viewed by visiting YouTube.

Type the following address into your web browser, to go directly to the video:  
<https://www.youtube.com/watch?v=JAgEDoVI-co>

Youtube Channel:  
[www.youtube.com/user/WiringHarness](http://www.youtube.com/user/WiringHarness)



The terminals that we supply in our kits, utilize what is known as an F crimp. The F crimp, in a cross section, will look like the illustration below, when done correctly.

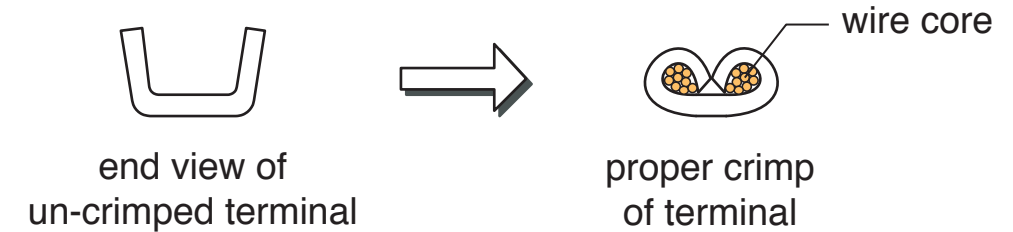

We carry the following crimping hand tools, to help with your terminal crimping. These hand tools are available, for purchase or rental.

AAW p/n 510585  
OEM small terminal crimping  
tool (18-14 Gauge)



AAW p/n 510586  
OEM large terminal crimping  
tool (12-8 Gauge)



AAW p/n 510609  
Weather Pack/Metri Pack  
crimping tool (18-12 Gauge)



**NOTE: DISCONNECT YOUR BATTERY:**

Disconnect the battery, before installing the wiring kit, to prevent any accidental shorting caused by loose bare wire ends.



If you have any questions concerning this or any of our products, please feel free to call us at 1-856-933-0801.

**510599**

# Relay Box Gray Input Connector and Black Input Connector installation instructions:

you may choose instead, to splice a number of the red 10 Gauge wires, to a larger gauge wire (8 Gauge or larger) and connect that single wire to your circuit breaker / battery (the larger gauge wire, splice and terminal required, are not supplied with this kit)

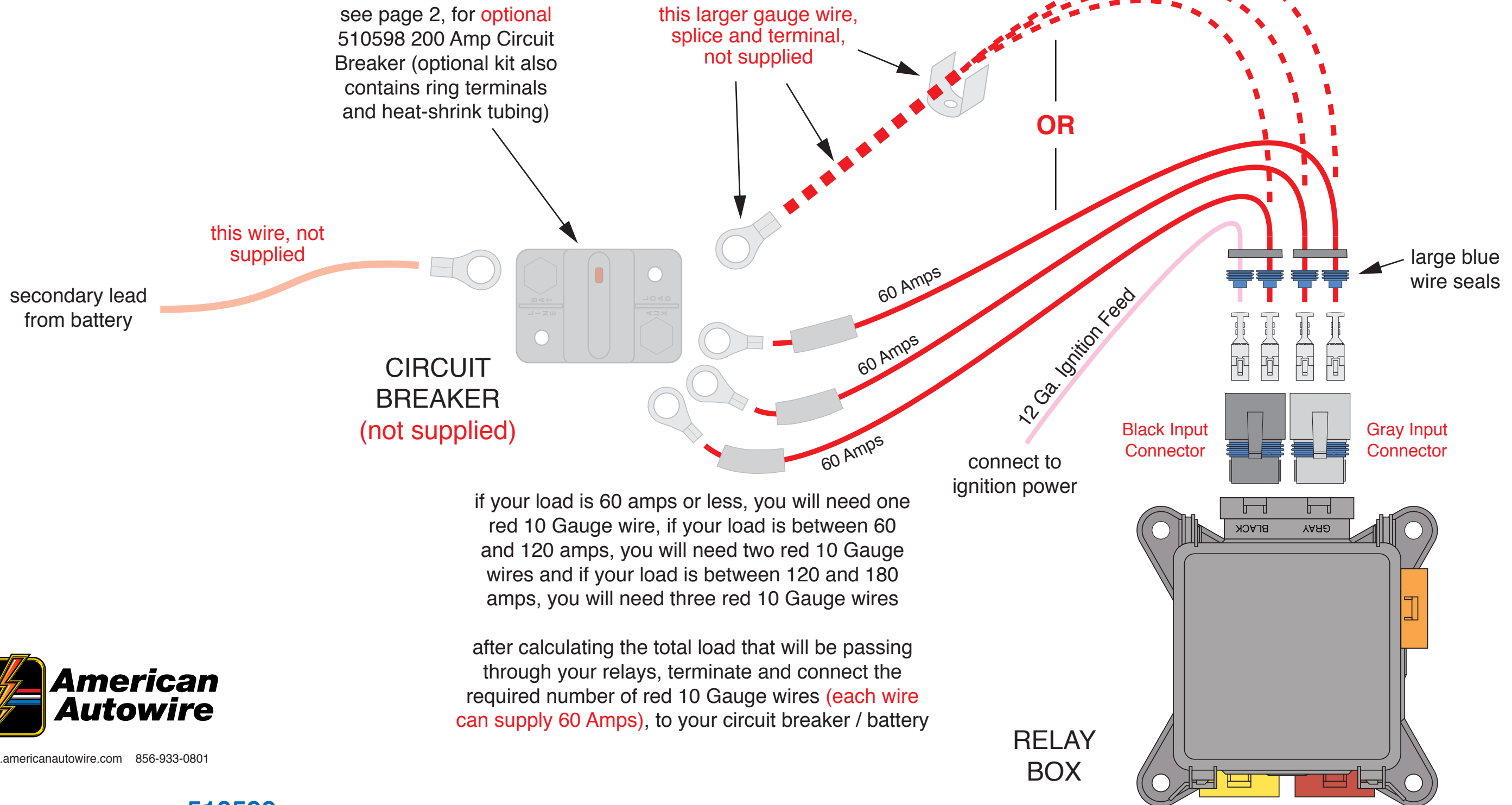

www.americanautowire.com 856-933-0801

# Relay Output Connector installation instructions:

Use the 16 Gauge (Gray) wire for up to **10 amps**.  
 Use the 14 Gauge (Orange) wire for up to **20 amps**.  
 Use the 12 Gauge (Red, Dk Blue, Dk Green, Yellow) wire for up to **30 amps**.

All **triggers** must be ground triggers, meaning that the switch activating the relay, must be passing ground. All (8) relays are only active when there is power on the **pink Ignition wire**, on the previous page. The **normally closed** contacts are battery "hot", anytime the red wires on the previous page are connected, until that specific relay is triggered, then that **normally closed** contact will open.

Relay	Fuse	Trigger	Wire Gauge (Color)	Wire Seal	Normally Open Contact	Wire Gauge (Color)	Wire Seal	Normally Closed Contact	Wire Gauge (Color)	Wire Seal	
1	F1	1D	18 Ga. (Pink, Lt Blue, Lt Green, Brown)	Green	1C	16 Ga. (Gray)	Gray	4B	16 Ga. (Gray)	Gray	
2	F3	1B			1A			4D			
3	F5	2D			2C			4G			
4	F7	2B			2A			4E			
5	F2	1E			12 Ga. (Red, Dk Blue, Dk Green, Yellow)	Blue	1F	NOT USED	4H	12 Ga. (Red, Dk Blue, Dk Green, Yellow)	Blue
6	F4	1G					1H	4F			
7	F6	2E					2F				
8	F8	2G					2H	NOT USED			

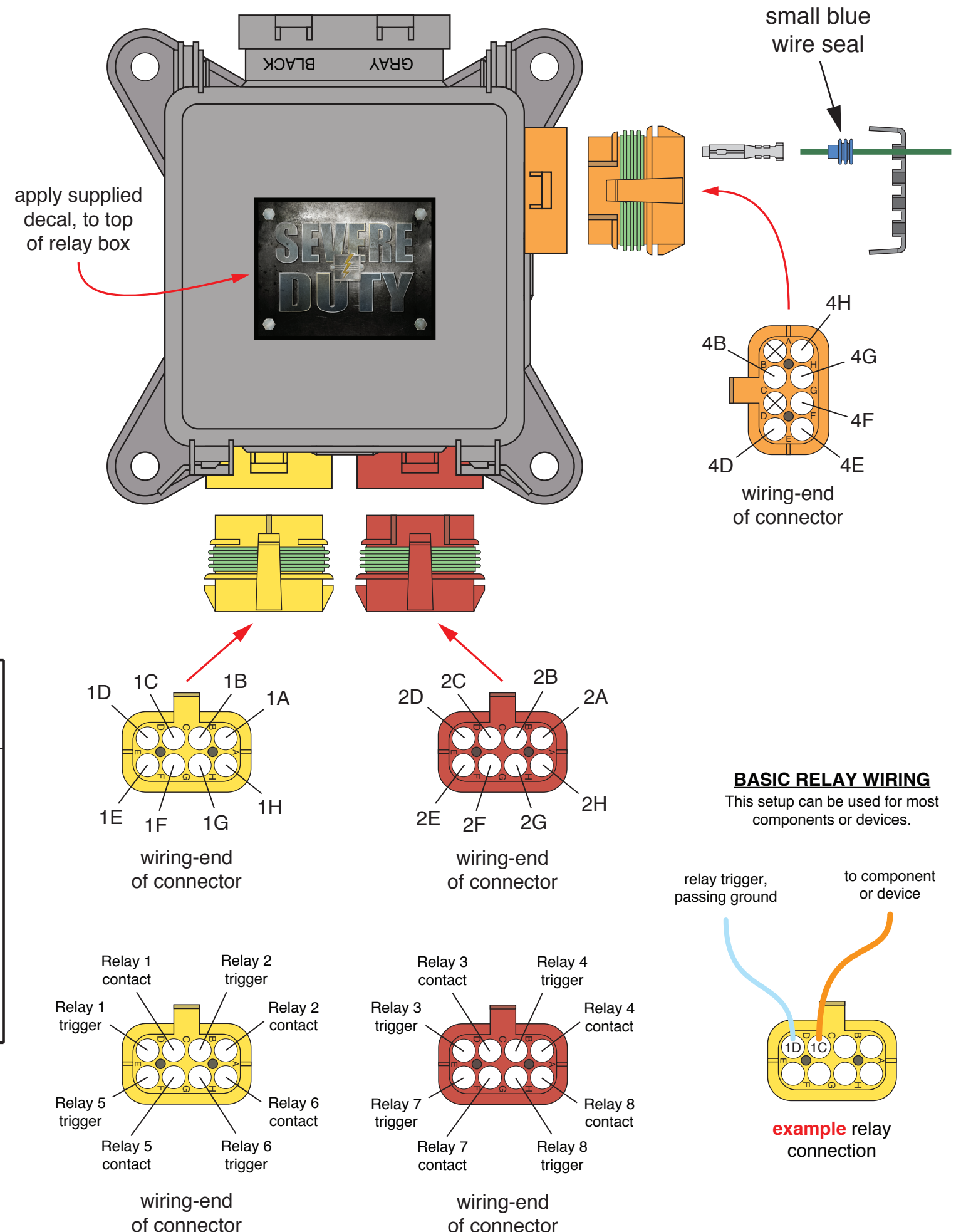

**BASIC RELAY WIRING**  
 This setup can be used for most components or devices.

# Relay Output Wiring Examples:

## FUEL PUMP RELAY WIRING

This setup removes the overload strain from the ignition switch, that an electric fuel pump can exert.

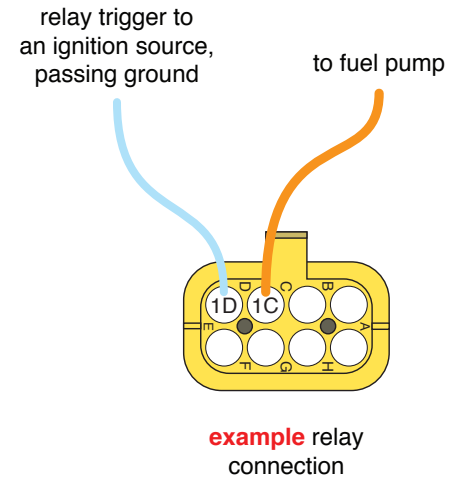

## ELECTRIC FAN WITH A/C TRINARY SWITCH RELAY WIRING

This setup turns the fan on with a fan temperature sender, a typical ground trigger A/C trinary switch, or a manual override.

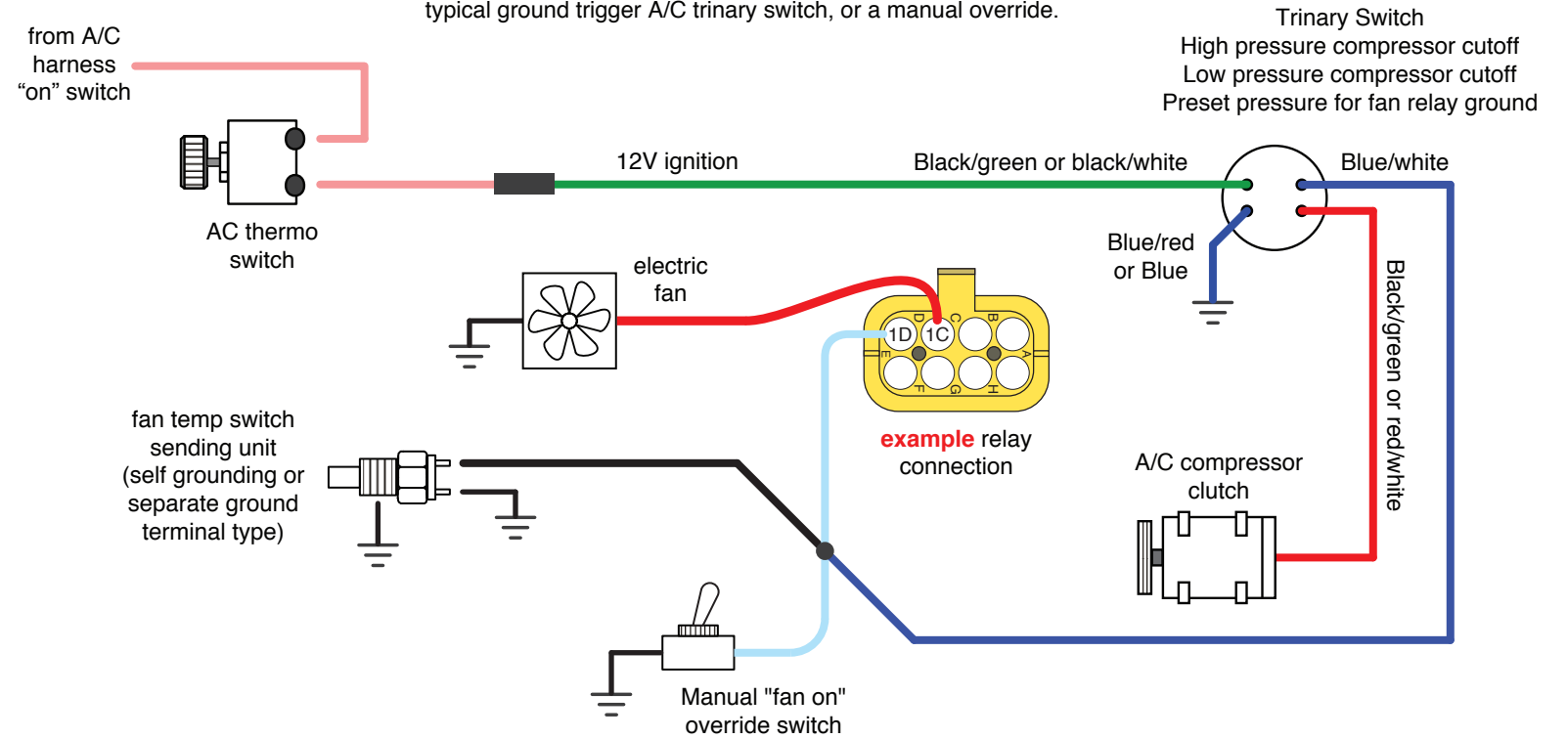

## ELECTRIC FAN RELAY WIRING

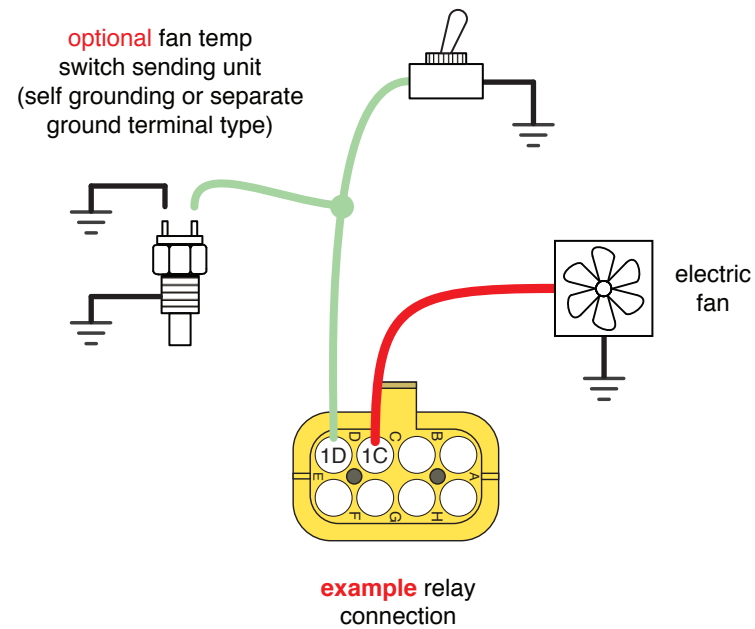

## DUAL ELECTRIC FAN ACTIVATION WITH A/C TRINARY SWITCH RELAY WIRING

If you have multiple fans, this setup will give you the option of turning them on with a single fan temp sender switch.

